

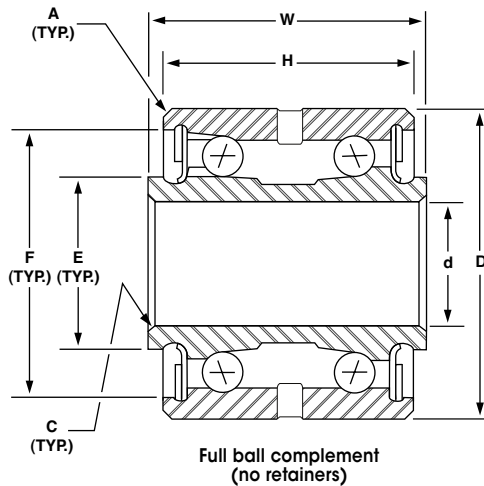

GDW-K, GDW- Series (AS27647)

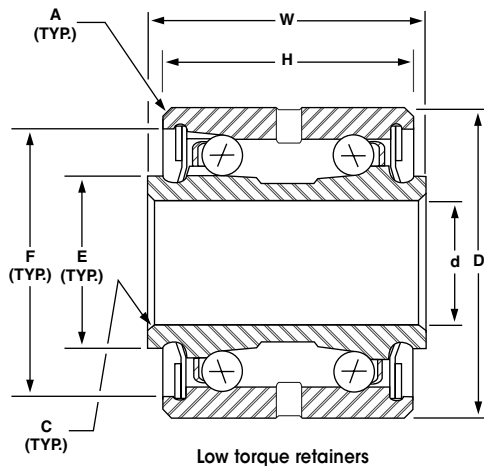

**Notes:**

1. Rings and balls are manufactured from premium quality AISI 52100 chrome steel.
2. Operating temperature range: -65 to +250 °F.
3. All bearings include removable PTFE seals.
4. Bearings are lubricated with MIL-PRF-81322 grease, 80% minimum fill, unless otherwise specified.
5. Contact angles are convergent ( / \ ).
6. Special feature: relubrication groove with grease holes.
7. External surfaces (except bore) are cadmium plated per AMS-QQ-P-416. All dimensions apply after plating.
8. Custom sizes, materials, tolerances, radial internal clearances, lubrication, plating, etc., are available upon request.
9. See "Airframe Part Numbering System" on page 5 for correct NHBB nomenclature.
10. All dimensions are in inches, unless otherwise specified.

Refer to the Qualifications and Manufacturing Schedule for a current list of the Precision Division's AS7949 qualifications and manufacturing capabilities.

GDW-K, GDW- (AS27647) — Qualified to SAE AS7949

NHBB BASIC P/N	MS27647-G DASH NO.	BORE d	O.D. D	RING WIDTH		BALL COMPLEMENT		RING SHOULDER DIAMETER		RING CHAMFER X 45°		LOAD RATINGS (LBS.)				APPROX. WEIGHT	MAX. STARTING TORQUE <sup>^</sup>
				OUTER H	INNER W	NO.	DIA.	OUTER F	INNER E	OUTER A	INNER C	STATIC		DYNAMIC RADIAL + RING ROTATION			
												RADIAL LIMIT	THRUST LIMIT	INNER	OUTER		
		+0.000 -0.005	+0.000 -0.005	+0.000 -0.005	+0.000 -0.005			REF.	REF.	+0.015 -0.000	+0.015 -0.000	RADIAL LIMIT	THRUST LIMIT			LBS.	OZ.-IN.
GDW4K2 <sup>(1)</sup>	-4AG	.2500	.6250	.500	.562	16	3/32	.523	.344	.016	.005	1400	500	1050	960	.025	1.0
GDW4K <sup>(1)</sup>	-4G	.2500	.7500	.750	.875	14	9/64	.648	.380	.016	.005	2770	900	2070	1850	.040	1.0
GDW4 <sup>(2)</sup>	(3)	.2500	.7500	.750	.875	24	1/8	.648	.378	.016	.005	3750	1240	2650	2300	.060	(4)
GDW5 <sup>(2)</sup>	-5G	.3125	.8750	.813	.938	26	9/64	.739	.468	.016	.005	5140	1600	2600	2320	.070	1.5
GDW6 <sup>(2)</sup>	-6G	.3750	1.0625	1.063	1.188	24	3/16	.916	.572	.016	.005	8440	2600	4220	3740	.120	2.5
GDW8 <sup>(2)</sup>	-8G	.5000	1.4375	1.375	1.500	22	17/64	1.223	.708	.032	.005	15520	4700	7610	6520	.290	2.5

Radial internal clearance: .0000 to .0010

- (1) Double row construction—low torque retainers
- (2) Double row construction—full ball complement (no retainers)
- (3) GDW4 equivalent not specified.
- (4) Torque limit not defined.

+ Dynamic radial load ratings are for operation up to 250 °F. Reduce load ratings by 20% for 250 to 350 °F operation. Dynamic radial load ratings are based on an average life of 10,000 complete 90° cycles.

<sup>^</sup> Torque limits are for bearings lubricated with MIL-PRF-81322 grease. For bearings lubricated with MIL-PRF-23827, multiply torque limits by a factor of 1.2.