

ROD END BEARINGS – Metal-to-Metal

3-Piece Heavy Duty – Male & Female Threads

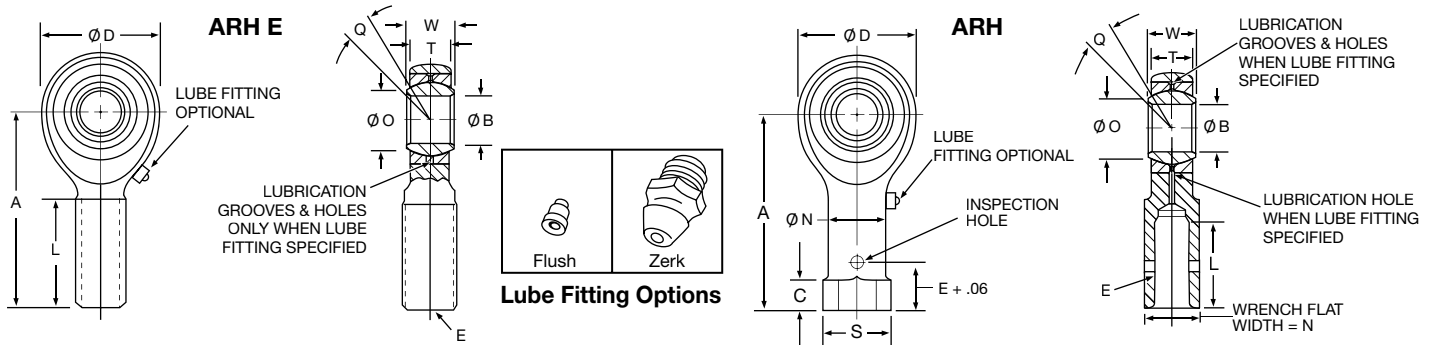

Part Number	(B)	(D)	(W)	(T)	(O)	Ball Diameter	(A)	(E)	(L)	(Q)	(N)	(S)	(C)	Static Radial Limit Load**		Weight
	Bore Diameter	Head Diameter	Ball Width	Body Width	Shoulder Diameter		Ball C/L to End	Thread Size	Thread Length	Misalignment	Shank Diameter	Flange Diameter	Flange Thickness	Steel Race	Bronze Race	
	Inch +.0005 -.0005	Inch +.010 -.010	Inch +.000 -.005	Inch +.005 -.005	Inch Ref.	Inch Ref.	Inch +.010 -.010	UNF - 3A* UNF - 3B*	Inch +.031 -.031		Inch Ref.	Inch Ref.	Inch +.010 -.062	lbs.	lbs.	lbs.
ARH4E	.2500	.806	.375	.337	.375	.531	1.562	5/16 - 24	.968	5°				6060	6060	.067
ARH4							1.469		.750		.485	.562	.188			.084
ARH5E	.3125	.900	.437	.327	.401	.593	1.875	3/8 - 24	1.187	14°				7290	7290	.095
ARH5							1.625		.875		.547	.625	.250			.102
ARH6E	.3750	1.025	.500	.416	.471	.687	1.938	7/16 - 20	1.187	9°				8860	8860	.140
ARH6							1.812		1.000		.610	.687	.250			.160
ARH7E	.4375	1.150	.562	.452	.542	.781	2.125	1/2 - 20	1.281	10°				9560	9560	.210
ARH7							2.000		1.125		.735	.875	.250			.230
ARH8E	.5000	1.337	.625	.515	.612	.875	2.438	5/8 - 18	1.468	9°				18560	18560	.330
ARH8							2.225		1.250		.860	1.000	.250			.340
ARH10E	.6250	1.525	.750	.577	.752	1.062	2.625	3/4 - 16	1.562	12°				20610	20610	.480
ARH10							2.500		1.375		.985	1.125	.375			.490
ARH12E	.7500	1.775	.875	.644	.892	1.250	2.875	7/8 - 14	1.687	13°				27640	27640	.730
ARH12							2.875		1.625		1.110	1.250	.375			.740

* UNF-3A = Male Thread, UNF-3B = Female Thread, per MIL-S-7742 Rev. D.

** Load ratings are based on male rod ends without lubrication fitting. For rod end load ratings with lubrication fittings please contact NHBB engineering department.

Notes:

- Radial Clearance: .002 max.
- † Plating: When specified in materials block, ball spherical diameter and ends are hard chrome plated per AMS-QQ-C-320, CL. 2 (.0002 to .0005 thickness). All external surfaces of race and/or body are cadmium plated per AMS-QQ-P-416.
- Unless otherwise noted, part number designation as shown furnished with CRES 410 race material. To specify CRES 17-4PH, add suffix "H" to designation. Example: ARH8ECRPLH or ARH8CRPLH.
- Dimensions: All dimensions apply after plating.
- Options: Radial clearance, lubrication holes and groove in ball, lubrication fittings, dry film lubrication, keyways, left hand or AS8879 threads see page 41.

Materials

Designation	Ball	Race	Body
Basic Part No.†	52100 Alloy Steel, H.T. & Chrome Plated	4130 Alloy Steel, H.T. & Cad. Plated	C.M. Steel, H.T. & Cad. Plated
Part No. + SS†	52100 Alloy Steel, H.T. & Chrome Plated	Stainless Steel† H.T.	C.M. Steel, H.T. & Cad. Plated
Part No. + CR†	CRES 440C H.T.	Stainless Steel† H.T.	CRES 17-4PH H.T.
Part No. + CRPL†	CRES 440C H.T. & Chrome Plated	Stainless Steel† H.T.	CRES 17-4PH H.T.
Part No. + 501†	52100 Alloy Steel H.T. & Chrome Plated	Aluminum Bronze (AMS 4635 and ASTM B 50/B150M) Cad. Plated	C.M. Steel, H.T. & Cad. Plated