

3-Piece High Misalignment – Male & Female Threads

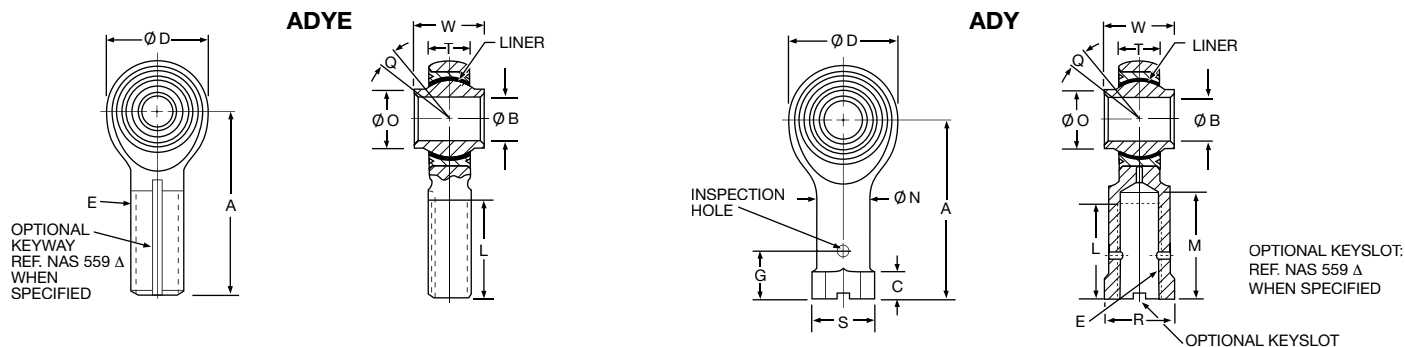

ΔFor keyway and keyslot details, refer to the engineering section, page 68-69.

Part Number	(B) Bore Diameter	(D) Head Diameter	(W) Ball Width	(T) Body Width	(O) Shoulder Diameter	Ball Diameter	(A) Ball C/L to End	(E) Thread Size	(Q) Mis-alignment	(L) Thread Length	(N) Shank Diameter	(R) Wrench Flat	(S) Flange Diameter	(C) Flange Thickness	(G) Drill C/L to End	No Load Rotational Breakaway Torque	Limit Static Radial Load	Weight
	Inch +0.0000 -0.0005	Inch Max.	Inch +0.000 -0.005	Inch +0.005 -0.005	Inch Ref.	Inch Ref.	Inch +0.06 -0.06	UNF - 3A* UNF - 3B*	Ref.	Inch +0.06 -0.06	Inch +0.010 -0.010	Inch Ref.	Inch Ref.	Inch +0.010 -0.062	Inch +0.002 -0.010	Inch - lbs.	lbs.	lbs. Ref.
ADYE3(L) ADY3(L)	.1900	.781	.560	.337	.301	.531	1.562 1.625	5/16 - 24	16°	1.000 .750	.500	.515	.562	.250	.375	0.5-6.0	2425	.07 .08
ADYE3-101(L) ADY3-101(L)	.1900	.750	.500	.220	.319	.437	1.500 1.375	5/16 - 24	15°	1.000 .750	.437	.452	.500	.250	.375	0.5-6.0	4060**	.07 .06
ADYE4(L) ADY4(L)	.2500	1.000	.593	.265	.390	.593	1.938 1.625	3/8 - 24	23°	1.250 .937	.562	.577	.625	.250	.437	1.0-15.0	7040**	.11 .11
ADYE5(L) ADY5(L)	.3125	1.125	.813	.355	.512	.781	2.125 1.812	7/16 - 20	23°	1.375 1.062	.625	.640	.688	.250	.500	1.0-15.0	8260	.16 .18
ADYE6(L) ADY6(L)	.3750	1.125	.813	.355	.512	.781	2.125 1.812	7/16 - 20	23°	1.375 1.062	.625	.640	.688	.250	.500	1.0-15.0	8260	.15 .17
ADYE7(L) ADY7(L)	.4375	1.312	.875	.355	.618	.875	2.437 2.125	1/2 - 20	22°	1.500 1.125	.750	.765	.812	.250	.562	1.0-15.0	12420	.25 .26
ADYE8(L) ADY8(L)	.5000	1.500	.937	.411	.730	1.000	2.625 2.625	5/8 - 18	20°	1.625 1.500	.875	.890	.938	.375	.687	1.0-15.0	17430	.39 .40
ADYE10(L) ADY10(L)	.6250	1.750	1.200	.577	.856	1.250	2.875 2.875	3/4 - 16	20°	1.750 1.750	1.000	1.015	1.125	.375	.812	1.0-15.0	23620	.62 .63
ADYE12(L) ADY12(L)	.7500	2.000	1.280	.630	.970	1.375	3.375 3.375	7/8 - 14	18°	1.875 1.875	1.125	1.140	1.250	.500	.937	1.0-24.0	30550	.90 .87
ADYE14(L) ADY14(L)	.8750	2.200	1.400	.635	1.140	1.531	3.750 3.750	7/8 - 14	18°	2.000 2.000	1.125	1.140	1.250	.500	.937	1.0-24.0	31970	1.08 1.01
ADYE16(L) ADY16(L)	1.0000	2.750	1.875	.845	1.278	1.875	4.125 4.125	1 1/4 - 12	21°	2.125 2.125	1.688	1.703	1.813	.562	1.312	1.0-24.0	59510	2.20 2.31
ADYE20(L) ADY20(L)	1.2500	3.125	1.875	1.015	1.523	2.250	5.000 5.000	1 1/4 - 12	21°	2.875 3.125	1.688	1.703	1.813	.562	1.312	1.0-24.0	70060	3.10 3.15

* UNF-3A = Male Thread. UNF-3B = Female Thread per MIL-S-7742, Rev. D.

** Load based on pin limitation.

Notes:

- †Plating: When specified in materials block, body cadmium plated all surfaces per AMS-QQ-P-416.
- Dimensions: Dimensions apply after plating.
- Temperature: Operating temperature range -65° to 350°F (ADY only).
- Qualifications: Liner is approved to AS81820 (ADY series only).
- Options:
 1. For left hand threads, add "L" to prefix. (Examples: ADYEL4(L) or ADYL4(L))
 2. For Keyway or keyslot options add suffix "W" to part number.
 3. For "J" form threads per AS8879, add suffix "J" to part number. (Examples: ADYE4JW(L) or ADY4JW(L))

Materials (ADYE & ADY)

Part No.	Ball	Race	Liner	Body
Catalog No.	CRES 440C AMS 5630 Rc55-62	CRES 17-4PH AMS 5643 Rc28-37	PTFE Fabric Bonded to Race I.D. No Lub.Required	4130 Alloy Steel H.T., and Cadmium Plated†
Catalog No. + SS	CRES 440C AMS 5630 Rc55-62	CRES 17-4PH AMS 5643 Rc28-37	PTFE Fabric Bonded to Race I.D. No Lub.Required	CRES 17-4PH AMS 5643 H.T., and Passivated

† Stainless Steel Series may be ordered to NHBB Part Number as indicated.